

# **BİZİM ORADA YAPILAŞMA ÖRNEKLERİ**

HAYDAR KARABEY

2015

BU ARSANIN SAHİPLERİ, EVLERİNİ YAPACAK  
İZİN NEDİR, NASIL PLANLASINLAR?

ARSA: 20m x 20m (400m<sup>2</sup>) YAPI: 10m x 10m (100m<sup>2</sup> x 2 kat)

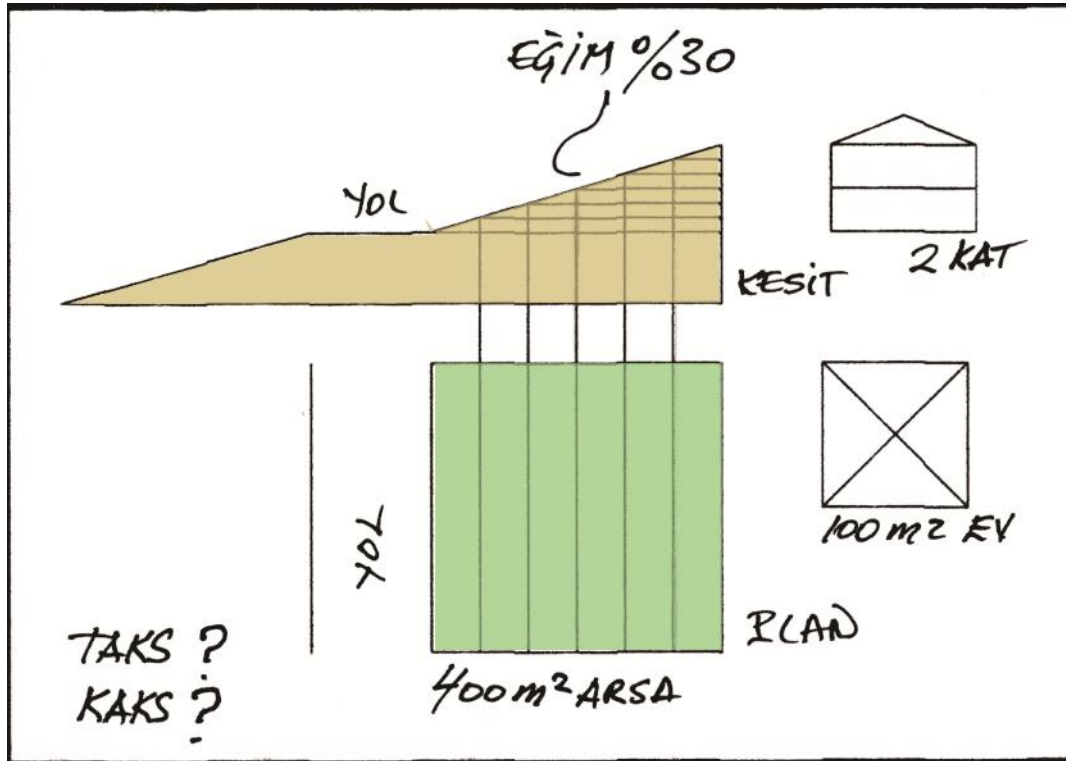

PLANA GÖRE İMAR HAKKI ALACAKLAR  
KAKS-TAKS-ÇEKME MESAFELERİ-ÇIKMALAR  
PLAN NOTLARI BUNLARI TANIMLAMALIDIR

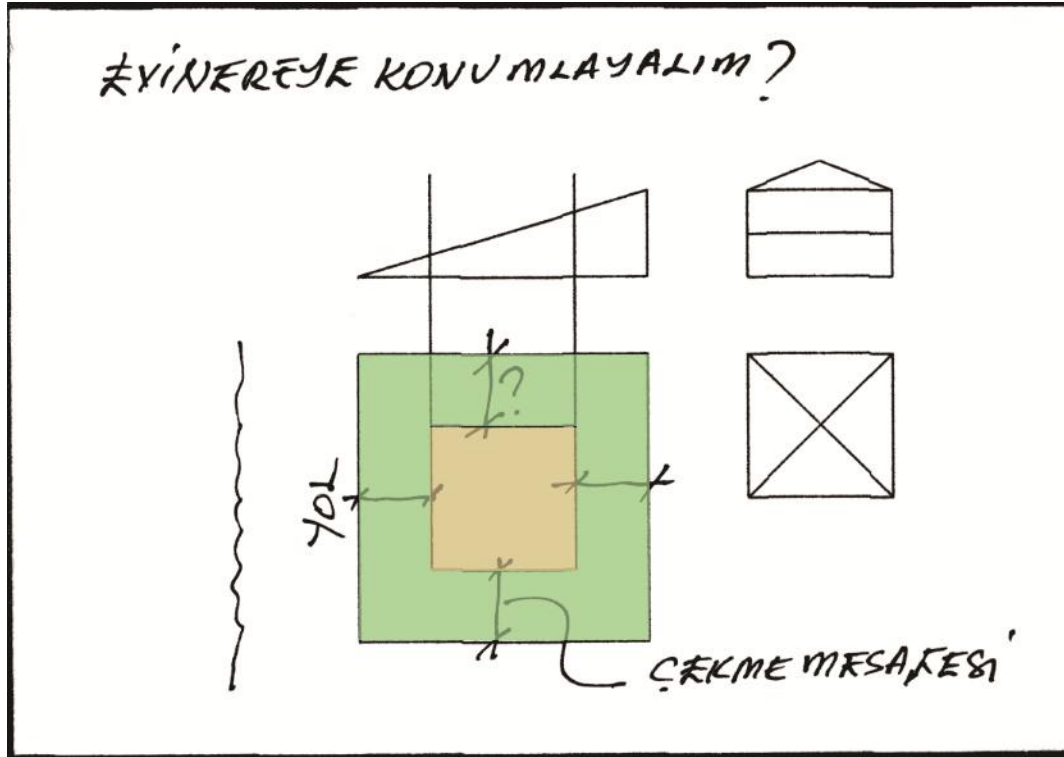

MANZARALI VE YÜKSEK KONUMDA OLSUN  
DOLGU İŞİ VAR AMA ORANIN İÇİNİ DE KULLANIRIZ  
DEPO-DÜKKAN?

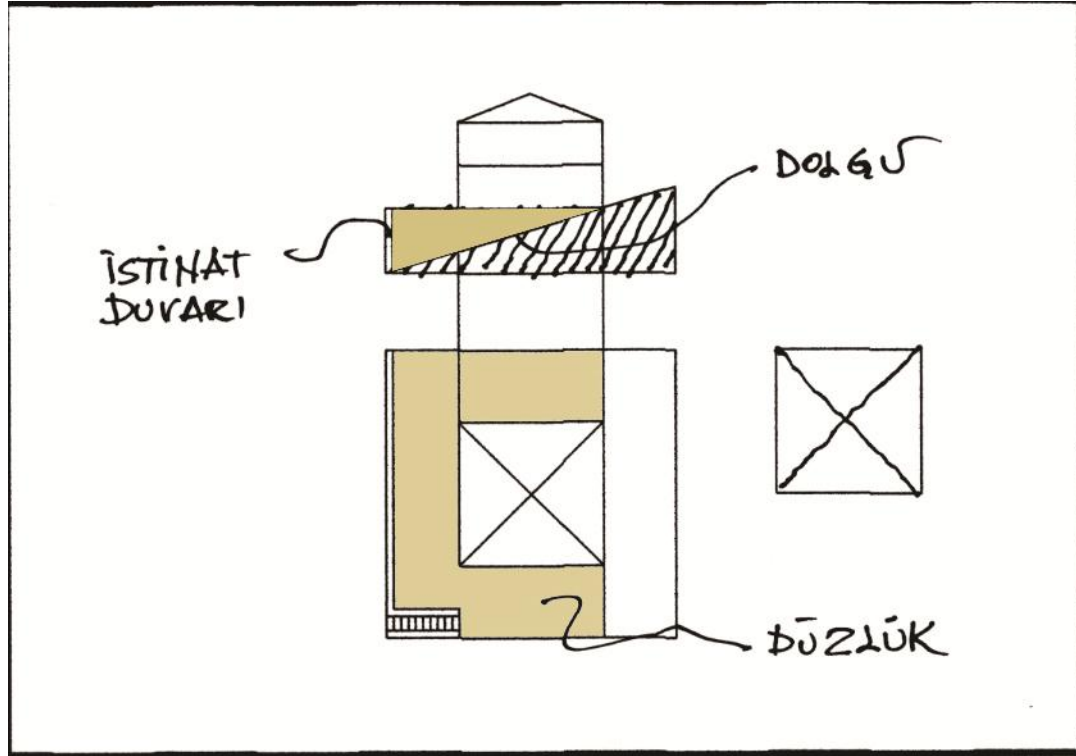

# SET OLUŐUR BAHÇEYE YOLDAN MERDİVENLE ÇIKILIR



# SETİN ALTINDA ÇOK YER VAR



# DOLGU YERİNE HAFRİYAT İLE DÜZLESEK?

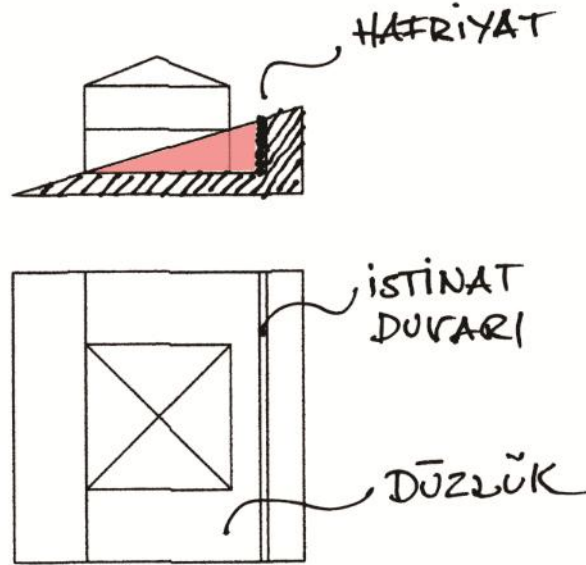

# ORTALAMA KOTTA YERLEŐMEK

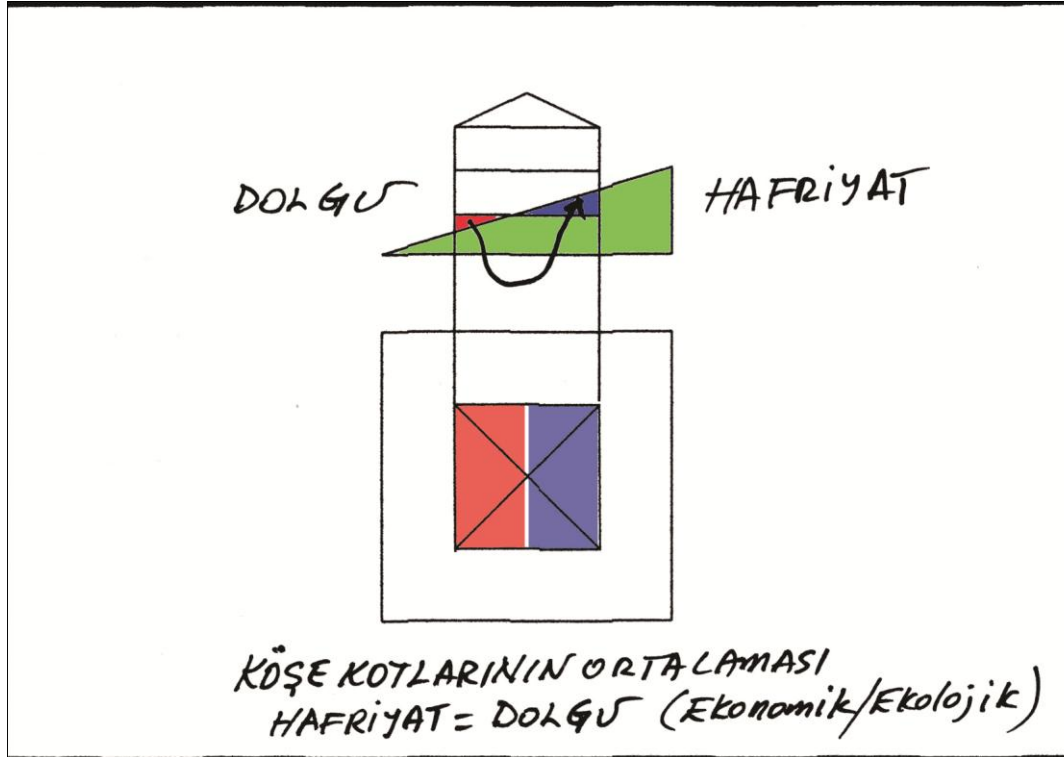

# DÜLGER BABAMIZ HAYATTA OLSA BÖYLE YAPARDI

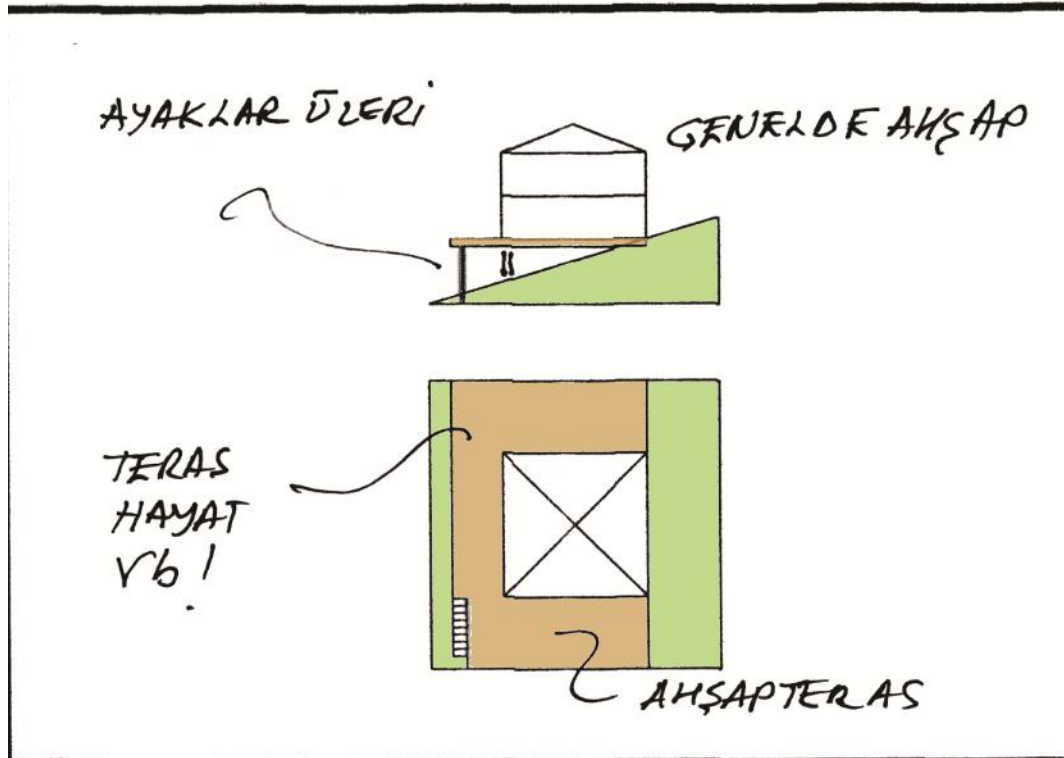

AMA ARTIK KİMSE BÖYLE BİR EV İSTEMİYOR



İKİ KAT (h:6.50) İZİNİMİZ VAR AMA EĞİMDEN BİR KAT KAZANSAK,  
KİRAYA VERİRİZ

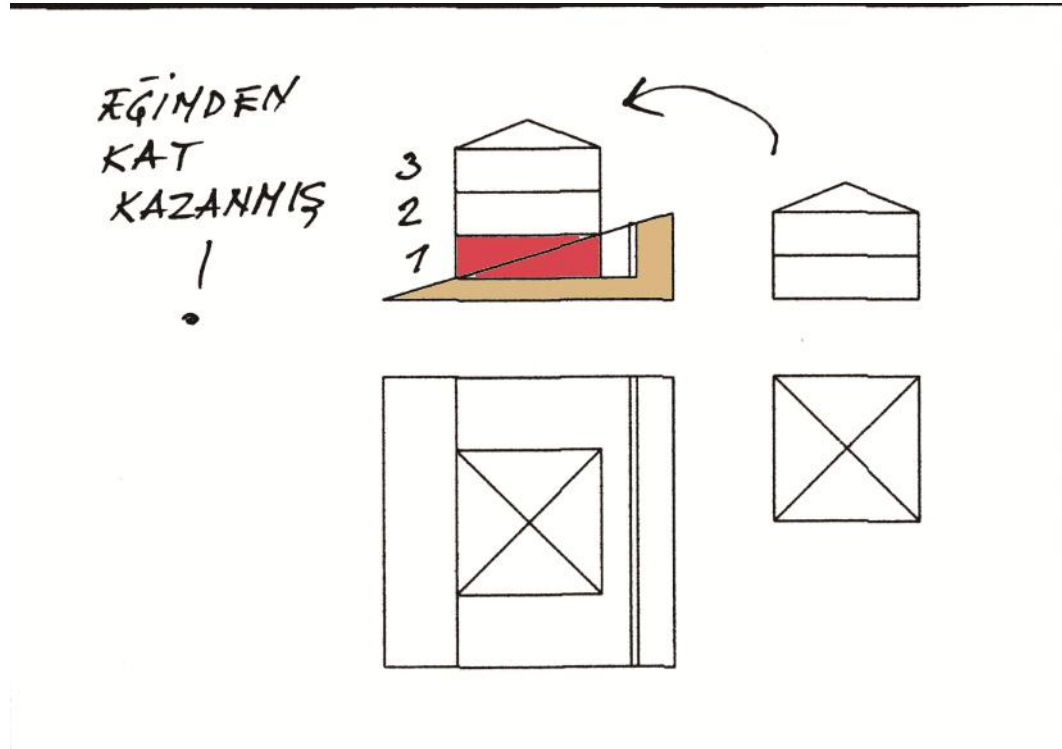

# ÜÇ KATI NASIL YERLEŞTİRSEK?

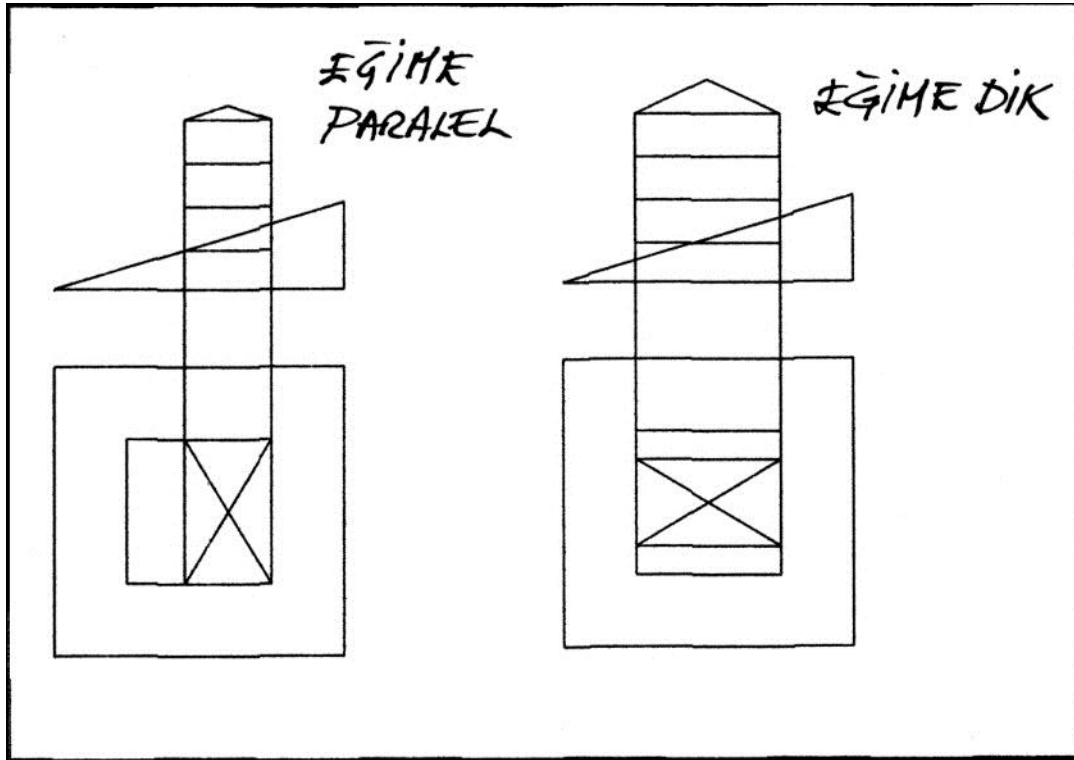

# BİZİM MAHALLE

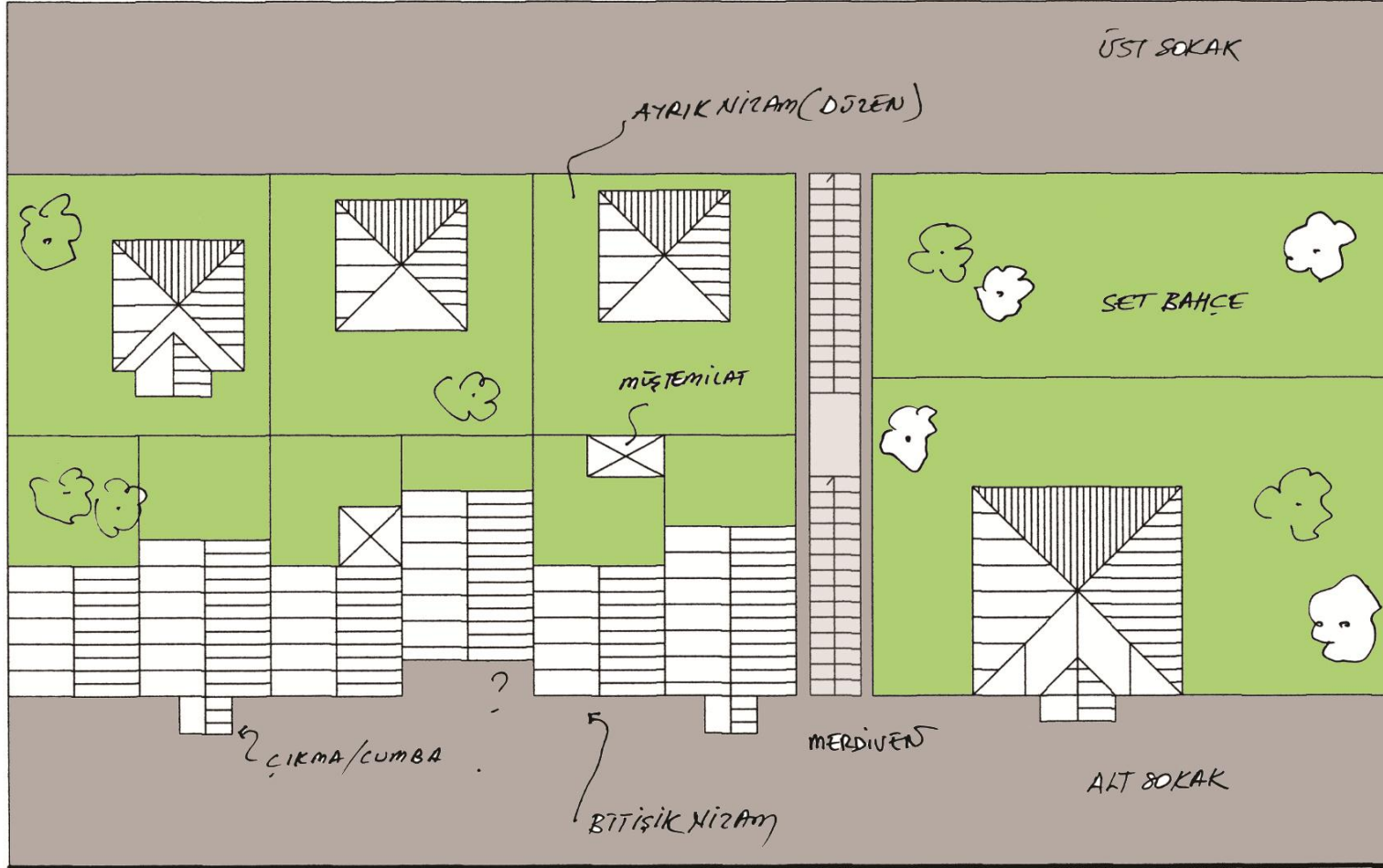

# ÜST SOKAK



# ALT SOKAK



# BAĞLAYAN MERDİVEN



# ASLINDA BURALAR O KADAR DA DÜZGÜN DEĞİL TABİ PLANCILAR «DÜZELTMEZSE!»

